

Magnuson 4th Generation MP90:

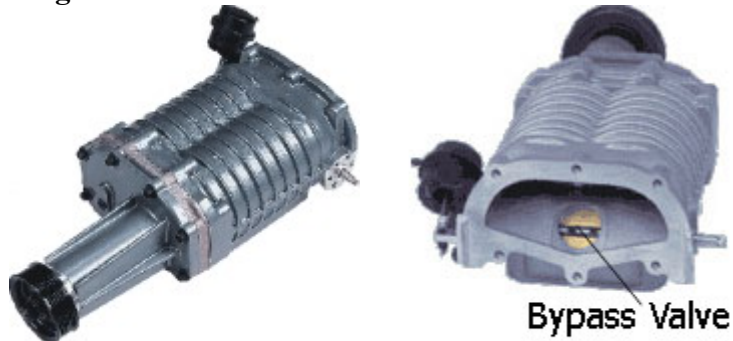

The Magnuson/Eaton Model MP90, 4th Generation is a “State of the Art” supercharger, engineered for 3.0 to 5.7 litre passenger cars and light truck engines. It was designed as a compact, flexible supercharger for increased power with original equipment quietness and reliability without adversely

affecting fuel economy.

The M90 has proven itself in a number of original equipment and aftermarket applications on a variety of engine sizes. This latest version has taken this versatility to the next level with “S Port” technology and a built in bypass for unparalleled performance.

- Most installations see a realistic 40% plus increase in power output.
- Eaton Superchargers will work effectively in any orientation (Flat, upside down, on edge).
- Different length drives are available, giving the custom installer flexibility in the placement of the supercharger.
- The bypass actuator can be located in any of 12 possible locations.

4th Generation Actuator Options

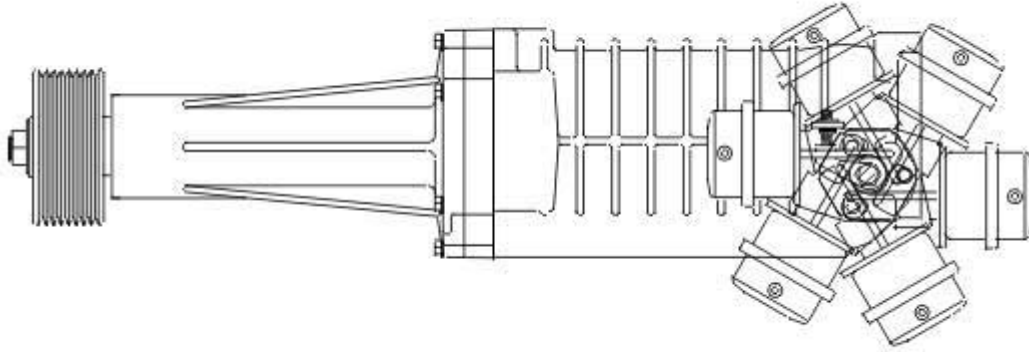

Actuator can mount in any one of 12 possible positions with 6 on each side.

MP90 4th Generation

Shown with standard one-piece drive. Other one-piece and variable length two piece drives are also available.

